



## TUFFAK DG – MAXIMIZE OPERATOR SAFETY AND VISIBILITY

### BARRIERS AND SURROUNDS – CLEARLY THE RIGHT CHOICE

TUFFAK DG polycarbonate sheet provides the durability required for partitions and barriers in buses without inhibiting operator vision.

- » Conforms to FMVSS 205/ANSI Z26.1, AS4
- » NHTSA approved for use as a protective driver partition
- » High impact resistance protects operator
- » Specified direction of extrusion for proper installation
- » Enables drivers to interact freely with passengers
- » Does not shatter into sharp-edged pieces like glass
- » High optical quality provides clear line-of-sight for operator
- » 2-sided abrasion resistant coating
- » Longer service life and exceptional durability compared to glass
- » Easy to fabricate and install-half the weight of glass
- » Easy to clean\*
- » 7 year limited product warranty

**\*See page 2 for information on disinfecting thermoplastics.**

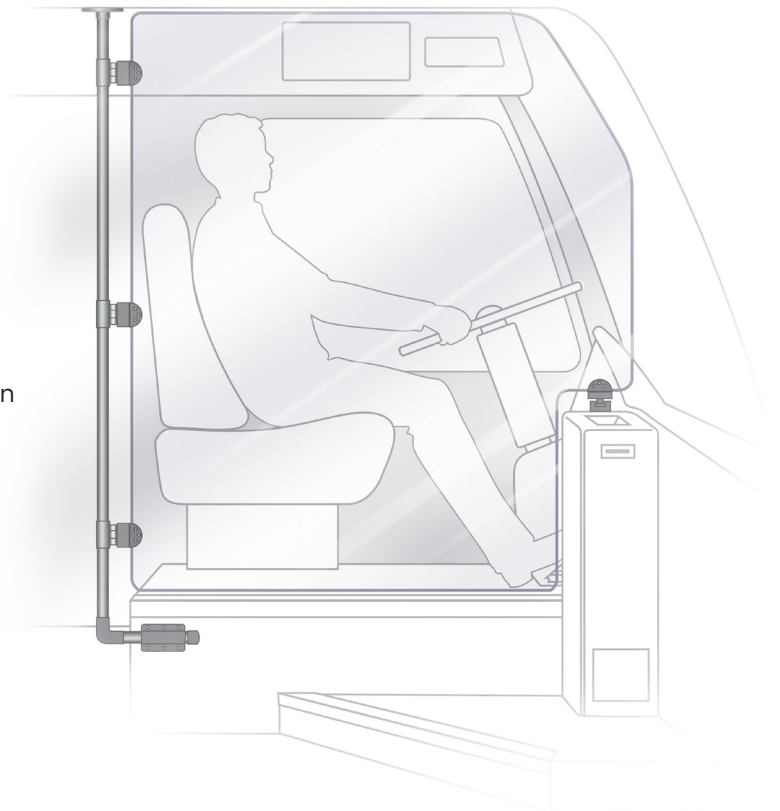

400 Nationwide Blvd, Suite 400  
Columbus, OH 43215  
800.848.9124 • Fax: 877.538.0754  
plaskolite@plaskolite.com  
www.plaskolite.com

**PLASKOLITE**

## DISINFECTING ACRYLIC, POLYCARBONATE AND PETG

When disinfecting OPTIX<sup>®</sup> Acrylic, TUFFAK<sup>®</sup> Polycarbonate and VIVAK<sup>®</sup> PETG, proper procedures should be taken. To minimize the risk of damage, use only compatible household

cleaners as outlined below. For more details please contact the Plaskolite Technical Service Group at **800.848.9124** with any questions.

### Disinfectants for Plaskolite Products

Product/Brand	Manufacturer	Products	Compatibility**
TUFFAK	sBioMed, LLC	Steriplex SD	Compatible
TUFFAK	Safetec of America	Safetec surface wipes	Compatible
TUFFAK	CONTEC Healthcare	Peridox RTU	Compatible
TUFFAK	CONTEC Healthcare	Prosat sterile wipes PS-911EB	Compatible
TUFFAK	Generic	Hydrogen peroxide 3%-5%	Compatible
TUFFAK	Generic	Isopropyl alcohol 70%	Compatible
TUFFAK	Generic	Warm dish washing soap solution	Compatible
OPTIX	Generic	Hydrogen peroxide 3%-5%	Compatible
OPTIX	Generic	Bleach - household laundry grade	Compatible
OPTIX	Generic	Quaternary ammonium compounds @ use dilution	Compatible
OPTIX	Generic	Isopropyl alcohol - diluted with water to 30% strength	Compatible
OPTIX	Generic	Warm dish washing soap solution	Compatible
VIVAK	Generic	Hydrogen peroxide 3%-5%	Compatible
VIVAK	Generic	Isopropyl alcohol 70%	Compatible
VIVAK	Generic	Warm dish washing soap solution	Compatible
TUFFAK	The Clorox Company	Clorox <sup>®</sup> health care bleach germicidal cleaner	Not Compatible
TUFFAK	Unimed Corp	Accel TB	Not Compatible
TUFFAK	The Clorox Company	Clorox <sup>®</sup> broad spectrum quaternary disinfectant cleaner	Not Compatible
TUFFAK	Zep Inc	ZEP 40	Not Compatible
TUFFAK	Zep Inc	ZEP Spirit II	Not Compatible
TUFFAK	PDI Inc	PDI Super Sani-Cloth	Not Compatible
TUFFAK	Reckitt Benckiser	Lysol disinfectant spray brand III original	Not Compatible
TUFFAK	Fiberlock Technologies Inc	Shockwave disinfectant	Not Compatible
TUFFAK	CONTEC Healthcare	Preempt RTU multi-surface disinfectant cleaner	Not Compatible
TUFFAK	The Clorox Company	Clorox <sup>®</sup> household bleach - all dilutions	Not Compatible
OPTIX	Generic	Ethyl alcohol - pharmacy grade	Not Compatible

**SPECIAL NOTES:** Cleaning products were tested on flat uncoated Tuffak Polycarbonate, Optix Acrylic and Vivak PETG sheet products. Do not use incompatible cleaners or disinfectants on sheet products. Generally speaking, soap and water or hydrogen peroxide disinfectants work best on these products.

\*\*Because manufacturers sometimes change their formulas without notification compatibility in perpetuity can not be presumed.

These suggestions and data are based on information we believe to be reliable. They are offered in good faith, but without guarantee, as conditions and methods of use are beyond our control. We recommend that the prospective user determine the suitability of our materials and suggestions before adopting them on a commercial scale.