



DuPont™ Vespel®

MACHINING GUIDE FOR VESPEL® POLYIMIDE PARTS



The miracles of science™

Table of Contents

Production Options	3
Suggested Tooling	4
Special Considerations	4
Sawing	4
Holding	5
Turning	5
Milling	6
Drilling	6
Threading	7
Grinding	7
Buffing and Polishing	8
Deburring	8
Lapping	8
Measuring Parts	8
Safety Precautions	8

Production Options to Meet Your Needs for Quality, High-Performance Parts



Tough, yet compliant DuPont™ Vespel® parts consistently perform in a range of physical environments that cause common materials to fail. Where trouble-free operation is key to commercial success, DuPont™ Vespel® parts can help keep your product running reliably.

DuPont™ Vespel® polyimide shapes are made by DuPont from high-performance SP and SCP polyimide resins, and are available as rods, tubes, plaques, rings, discs and/or bars. This brochure is designed to help you obtain the best possible results in machining DuPont™ Vespel® parts from these shapes.

Parts machined from DuPont™ Vespel® shapes are ideal for prototype, low volume or complex geometry parts. Keep in mind, though, that if you need more than 500 parts at a time, they can often be manufactured more cost effectively by DuPont using our “direct-forming” process. For more information on direct-formed DuPont™ Vespel® parts, contact DuPont™ Vespel® at:

DuPont™ Vespel®
Pencader Site
Newark, DE 19714-6100
Tel: 800-222-VESP (8377)
Fax: (302) 999-2311

Email: web-inquiries.DDF@usa.dupont.com
Web: vespel.dupont.com

General Machining Procedures

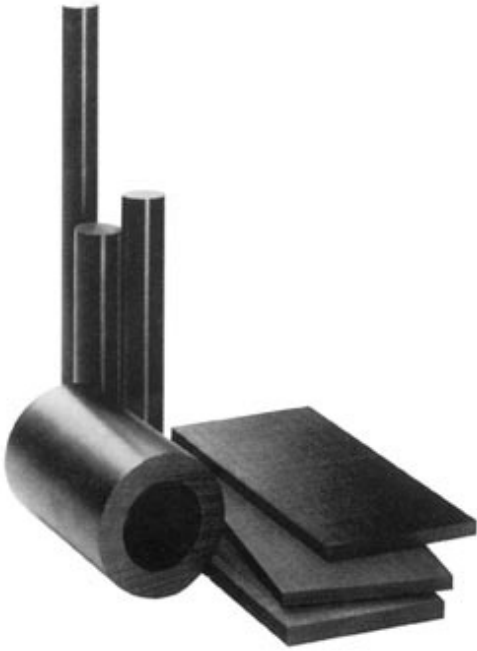

DuPont™ Vespel® shapes are relatively easy to machine because of their inherent mechanical strength, stiffness and dimensional stability at machining temperatures. In addition, they can be machined with standard metalworking equipment to produce parts to tolerances once considered too close for plastic materials. In most cases, the techniques used in machining metals are directly applicable.

Suggested Tooling

- **Carbide Tooling** — C-2 grade
- **Kennametal K-11, Carboloy 895 or equivalent** — When tool life is particularly important.
- **Diamond tooling suggested for large volume runs**

Special Considerations

- **Overheating** — Do not allow the material to get so hot that it is uncomfortable to grasp with your bare hands. If overheating occurs, sharpen the tool and/or reduce the feed rate.
- **Light Work** — Use tools that work well with brass.
- **Tool Chatter** — Tools should have a 0° to 5° positive back rake angle and 0° to 5° back rake angle to reduce the possibility of tool chatter.
- **Special Sizes** — Large diameter (2½ inch or 64 mm) or thin wall (1/8 inch or 3.2 mm) DuPont™ Vespel® parts have been successfully machined to close tolerances. To maintain dimensional stability, the part can be rough-machined to within 0.015 inch (0.4–0.5 mm) of finished size, then equilibrated to 70°F (294 K) and 50% relative humidity before final machining.

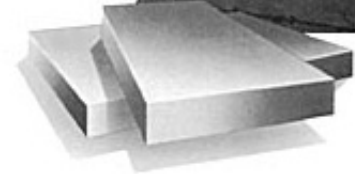
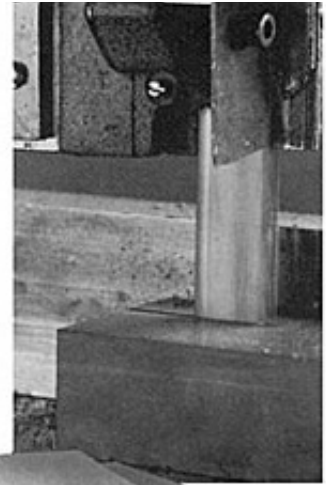

Sawing rectangular stock

Sawing

DuPont™ Vespel® shapes cut easily with band saws. Follow these suggestions for best results.

Band Sawing:

- Sections of DuPont™ Vespel® five inches thick can be cut on a vertical or horizontal band saw without coolant, using a sharp 10 teeth/inch blade with standard set.
- Finer blades can be used for cutting thinner sections.
- Use special alloy blades for most filled compositions.

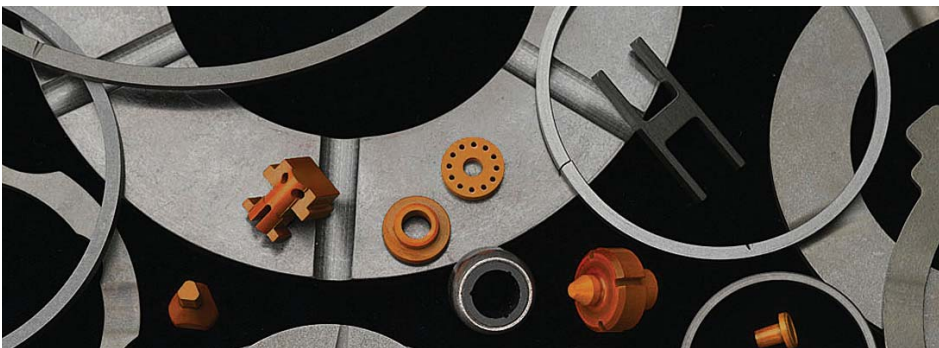

General Machining Procedures



Six-jaw chuck holding cylindrical stock

Holding

The main precaution in holding DuPont™ Vespel® shapes for machining is to prevent any deflection caused by the holding fixture, collet or chuck.

Unlike metal, plastics (including DuPont™ Vespel®), will deform if held too tightly.

Reliable Holding Methods:

- **O.D. or I.D. Collet** — This is the most reliable holding device with sufficient pressure to ensure a good hold.
- **Chuck** — Six-jaw type is suggested to distribute the holding force.

Turning

To produce good machining finishes on turned DuPont™ Vespel® parts, follow these suggestions:

- Turn using standard lathe, chucker or screw machine techniques.
- Use carbide-tipped or diamond tipped tools for work requiring close tolerances.
- Chip-breaker designed tools work well.
- Keep tool cutting edges sharp, with a nose radius of 0.003 inch to 0.008 inch (0.08–0.2 mm). Ensure sharpness by examining the cutting edge under 10× magnification, and hone the edge and nose radius with an 800-grit diamond hand hone if necessary.
- Speeds in the range of those used in the machining of brass are suggested. Stock speed can be varied over a wide range with good results.
- A coolant may be used to minimize thermal effects and maintain dimensional stability.
- Chattering could indicate a dull cutting tool or tool is extended too far from holder.

Table 1: Lathe Operating Conditions

	Cross Feed per Revolution	
	Inches	Millimeters
Rough Turning and Facing	0.010–0.020	0.25–0.51
Finish Turning and Facing	0.001–0.005	0.025–0.13
Rough Boring	0.010–0.020	0.25–0.51
Finish Boring	0.001–0.003	0.025–0.076
Parting	0.003–0.008	0.076–0.20

Figure 1: Lathe Tool

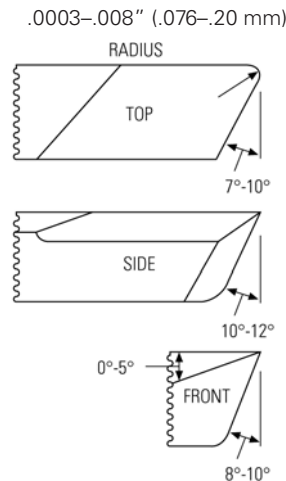

Lathe tool 0.075 – 0.20 mm

Note: Tool must be very sharp for good finish



Turning cylindrical stock in a lathe

General Machining Procedures

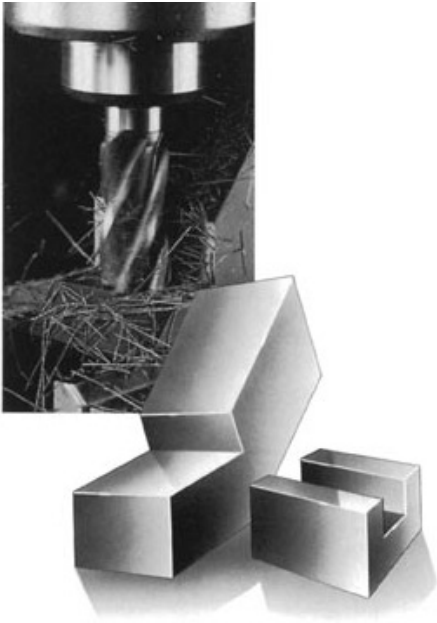

Grove Cutting with a Milling Machine

Milling

In general, milling operations which are used on metals may be used on DuPont™ Vespel® shapes. Exercise the same precautions regarding heat build-up, care in holding, sharpness of tools, avoiding dust inhalation, etc.

Avoid edge chipping by:

- Backing up edges with some other material.
- Climb milling.
- Slowing cross feed to no more than 2 inches per minute when breaking through an edge.
- Using fly cutters whenever possible, as they work especially well.

Avoiding Chipout

To drill thin cross sections without chipout, follow these suggestions:

Use a drill with a 5° end relief or end mill. Feed automatically, if possible, or ease off feed pressure at breakthrough. Cutting speeds of 40–50 ft per min should produce acceptable results.



Clean Edge



Clean Chipping

Table 2: Milling

	Rough	Finish
Cross Feed	0.010 inch/rev (0.25 mm/rev)	0.002 inch/rev (0.05 mm/rev)
Down Feed	0.010 inch/rev (0.25 mm/rev)	0.002 inch/rev (0.05 mm/rev)
Depth of Cut	Up to 0.250 inch/rev (6.4 mm/rev)	Up to 0.020 inch/rev (0.51 mm/rev)

Drilling

DuPont™ Vespel® parts are more elastic and some grades have a higher coefficient of thermal expansion than metal; because of this, they have a greater likelihood of seizing than metal. Depending on your application, the following drills and drill modifications can reduce the possibility of seizing.

- **Standard twist drill** — May be used to drill shallow holes (up to about one-half of the drill diameter in depth). Drilling holes deeper than one-half the drill diameter increases the risk of seizing.
- **Modified drill** — Differs from the standard twist drill in several ways:

Diameter is reduced along the full length of the drill body except for the leading 1/8 inch (3.2 mm) behind the lands.

Lip clearance is increased to 25–30° (versus standard 12–15°).

On drills, 1 inch (25 mm) diameter and larger, the thickness of the standard drill web could be reduced.

Use rates normally employed in cutting mild steels so that holes cut have good surface finishes.

- **Spade drills** — Give good surface finishes and reduced chipping when drill breaks through to other side.

Close Tolerances

Deep blind holes are difficult to manufacture to close tolerances. Rough drill and bore whenever possible. Gun drills may be used with high pressure coolant to help remove chip buildup.

Figure 2: Modified Drill For Vespel® Shapes

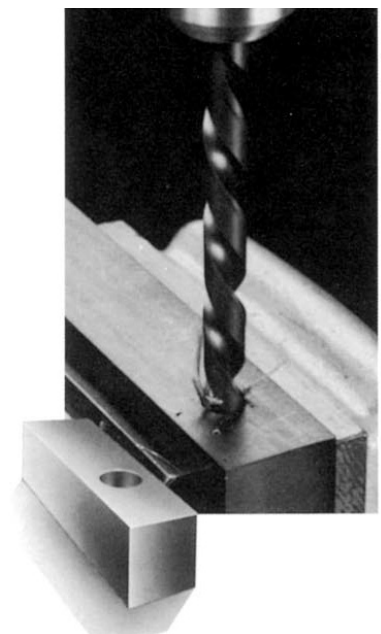
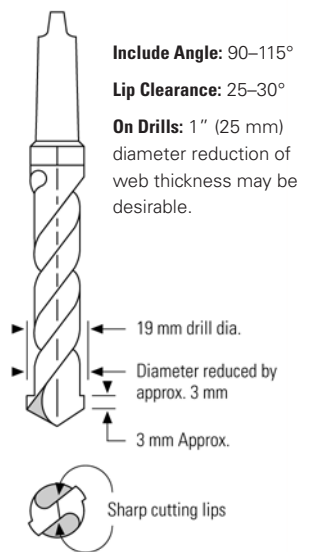

Drill press operation

General Machining Procedures

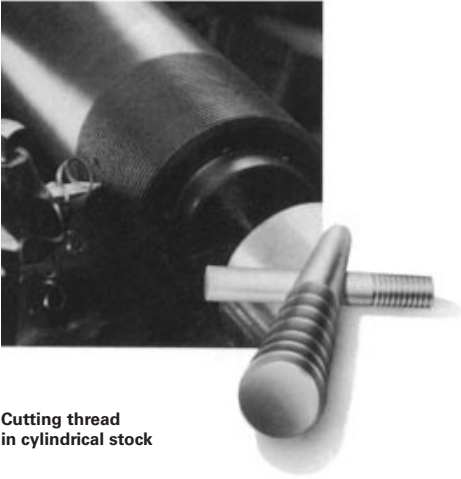

Cutting thread
in cylindrical stock

Threading

DuPont™ Vespel® shapes can be threaded using standard metal-cutting taps. The metal should not be allowed to heat to a point where thermal expansion will cause binding of the tap. Threads should be chased using a single point carbide tool and 30° compound feed whenever possible. The depth of feed should not exceed 0.005 inch (0.13 mm) on first pass and gradual reduction to 0.002 inch (0.05 mm) per pass until complete. Although this procedure will add additional cycle times to individual part production, it assures good thread quality results.

Grinding

DuPont™ Vespel® shapes can be ground to close tolerances on surface, double disc or centerless grinders at a table surface speed of approximately 80 ft/min (24m/min) for rough cuts and about half the speed for finish grinding on surface grinders. A 12 inch diameter 32A46-H8VG wheel works well at surface speeds of 3,000–4,000 ft/min (900–1200 m/min). The wheel should be diamond dressed as for finish grinding of steel.

DuPont™ Vespel® rods and small tubes can be prepared for chucker and screw machine stock by centerless grinding. Standard setups used for steel with plenty of coolant flow are usually adequate.

Caution: Do not allow material to get hotter than is comfortable to handle with bare hands.

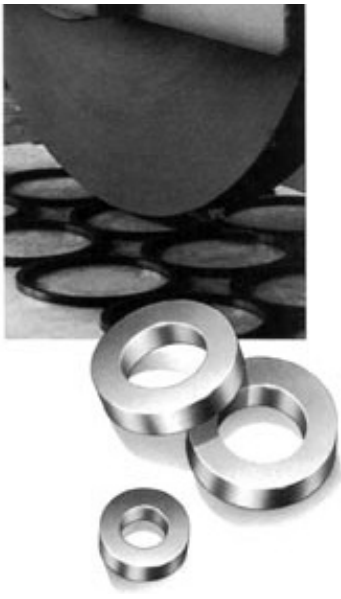

Grinding DuPont™ Vespel® rings

Table 3: Operating Conditions—Grinding

	Rough	Finish
Table Surface Speed	80 ft/min (24 m/min)	40 ft/min (12.2 m/min)
Transverse Feed	0.060 inch (1.5 mm)	0.005–0.060 inch (0.13–1.5 mm)
Down Feed	0.100–0.015 inch (2.5–.38 mm)	0.001–0.0005 inch (0.025–0.013 mm)
Wheel Surface Speed	3000–4000 ft/min (915–1219 m/min)	3000–4000 ft/min (914–1219 m/min)

General Machining Procedures

Buffing and Polishing

DuPont™ Vespel® parts can be polished to a high gloss with conventional muslin wheels. No special precautions are necessary beyond those normally practiced in this operation.

Deburring

Burrs can be removed using the same methods used on metal parts. DuPont™ Vespel® parts may also be tumbled in vibratory or rotating deburring equipment, along with abrasive media, tumbling detergent and water. Thin walls or pointed surfaces with angles less than 90 degrees may experience chipping if tumbled. Hand deburring may be required. Another option for lapping is a diamond lapping block with 320 grit.

Lapping

To avoid impregnating DuPont™ Vespel® shapes with diamond or aluminum oxide compounds, follow these lapping suggestions for flat, highly polished surfaces:

- Use a wet or dry abrasive paper (such as 600 grit Norton Tufbak® Durite®) where the grit will be contained.
- Use a granite surface plate or equivalent to maintain flatness.
- Light machine oil can be used as a vehicle.
- Final lapping with crocus cloth will result in a finer finish.
- Additional surface polish can be obtained by lapping the DuPont™ Vespel® shapes on Kraft or tablet paper.

Measuring Parts

Although the same tools used to measure metal parts can be used to measure DuPont™ Vespel® parts, techniques differ because of the possibilities of greater deflection of plastic parts under the stress applied during measurement. Parts should be conditioned in accordance with ASTM D618-08, in which test specimens

are allowed to remain at a standard laboratory atmosphere for a minimum of 40 hours ($73.4^{\circ} \pm 3.6^{\circ}\text{F}$ with a relative humidity of $50\% \pm 5\%$). Tight tolerances may require parts to be machined and measured in a controlled environment.

Micrometer

When measuring the O.D. of a ring, do not use the micrometer in the usual fashion (twisting the barrel until it feels snug or until the ratchet slips) as this may actually deform the part, causing an incorrect reading. Instead, set the micrometer at the minimum reading of the tolerance and try passing the part through the gap, using the micrometer as a “no go” gauge. Use the same procedure for the upper tolerance limit, using the micrometer as a “go” gauge. The part should pass through without any pressure applied. To minimize distortion of thin-walled cross sections, a correctly-sized I.D. plug may be inserted into the part.

Plug Gauge

When measuring hole sizes with a plug gauge, avoid forcing the plug into the hole, as it is entirely possible to force a plug gauge into a hole as much as 0.004 inch (0.10 mm) under the plug gauge size, depending on the part design. Generally, plug gauges are better than hole micrometers because of the deformation



Measuring parts

the micrometers may cause. Air gauges work well for measuring internal diameters.

Figure 4: “Go—“No Go” Gauge

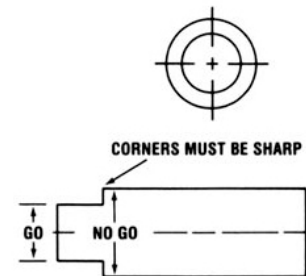

Safety Precautions for Machining DuPont™ Teflon® Filled SP-211 and SP-221

DuPont™ Vespel® parts and shapes made from SP-211 and SP-221 resins contain 10% and 15% DuPont™ Teflon® PTFE resin by weight, respectively. Because PTFE particles can become airborne during machining operations, the following precautions should be observed.

- When machining or cutting, use coolant—preferably cutting oil or water soluble coolant oil. Do not sand SP-211 or SP-221 without adequate ventilation equipment.
- Keep materials for smoking, such as cigarettes and pipes, out of the immediate machining area, as airborne particles of PTFE may contaminate them.
- Avoid inhaling dust, and wash hands thoroughly before smoking or eating.

Americas

DuPont™ Vespel®
Pencader Site
Newark, DE 19714-6100
Tel: 800-222-VESP
Fax: (302) 733-8137

DuPont do Brasil, S.A.
Alameda Itapecuru, 506
06454-080 Barueri, SP Brasil
Tel: +55 11 4166 8542
Fax: +55 11 4166 8720

Asia Pacific

DuPont (China) Research & Development
Management Co., Ltd
Zhangjiang Hi-Tech Park 600 Caliu Road,
Pudong New District,
Shanghai 201203, China
Tel: +86 400-888-0256
Fax: +86 21 28921234

DuPont K.K./DuPont Asia Pacific
Sanno Park Tower
11-1 Nagatacho 2-chome
Chiyoda-ku, Tokyo, 100-6111 Japan
Tel: +81 3 5521 2773
Fax: +81 3 5521 2775

DuPont Korea Inc.
3~5th Floor, Asia Tower
#726 Yeoksam-dong, Kangnam-ku
Seoul 135-719, Korea
Tel: +82 2 2222 5463
Fax +82 2 2222 5479

Europe/Middle East/Africa

DuPont de Nemours
(Belgium) BVBA-SPRL
Engineered Parts Center
A. Spinoystraat 6
B-2800 Mechelen Belgium
Tel: ++32 15 441384
Fax: ++32 15 441408

For more information, visit: vespel.dupont.com

The data listed here fall within the normal range of properties, but they should not be used to establish specification limits nor used alone as the basis of design. The DuPont Company assumes no obligations or liability for any advice furnished or for any results obtained with respect to this information. All such advice is given and accepted at the buyer's risk. The disclosure of information herein is not a license to operate under, or a recommendation to infringe, any patent of DuPont or others. Since DuPont cannot anticipate all variations in actual end-use conditions, DuPont makes no warranties and assumes no liability in connection with any use of this information.

CAUTION: This product is not permitted to be sold for use in medical applications involving any implantation in the human body or where contact with internal body fluids or tissues will equal or exceed 24 hours. For applications involving contact of less than 24 hours, see "DuPont Medical Caution Statement" H-50102 or contact your DuPont sales representative.

Copyright © 2009 DuPont. The DuPont Oval Logo, DuPont®, The miracles of science™, Teflon® and Vespel® are registered trademarks or trademarks of E.I. du Pont de Nemours and Company or its affiliates. All rights reserved.

K-22000 (05/6/09 rev2) Printed in the U.S.A.



The miracles of science™

Curbell Plastics is a proud supplier
of DuPont™ Vespel® Polyimide Shapes

CURBELL
CURBELL PLASTICS, INC.

Nationwide
1.888.CURBELL
www.curbellplastics.com